

Kompakt-Hochregallager

Compact High Level Storage Warehouse

Artikel-Nr. *Article No.* 226001

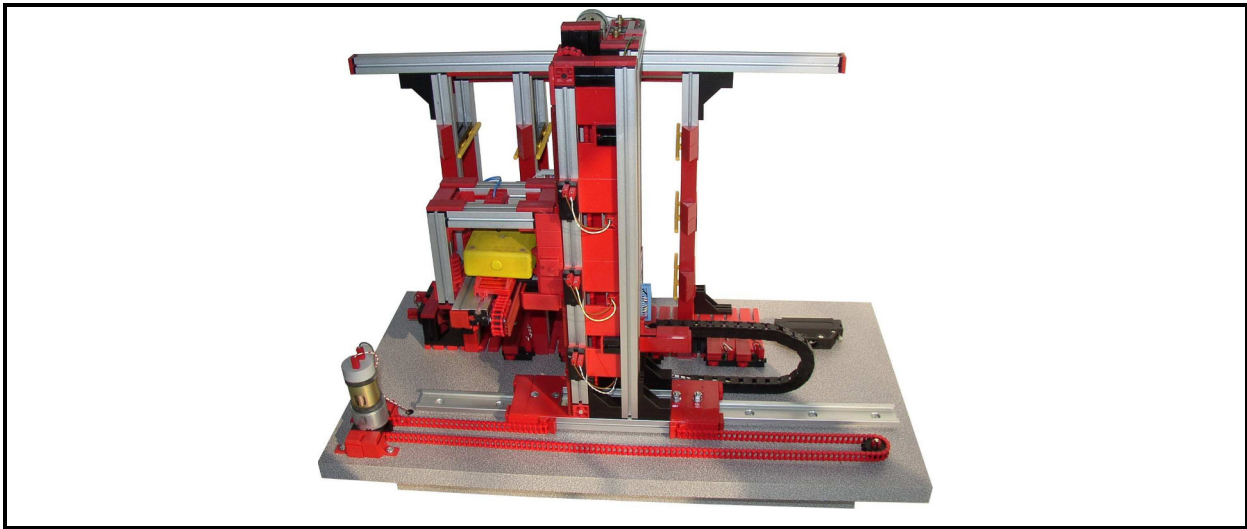

Das Modell Kompakt-Hochregallager simuliert ein automatisches Hochregallagersystem, wie es in vielen Industriebereichen Anwendung findet. Das Modell besteht aus einem Hochregal mit 3 x 3 Lagerplätzen, einem in X-Richtung verfahrbaren Regalbediengerät. Am Regalbediengerät ist ein in Z-Richtung verfahrbarer Korb angebracht, in dem sich der in Y-Richtung verfahrbare Teleskoptisch mit der Palettenaufnahme befindet. Im Simulationsablauf werden Paletten im Hochregal ein- und ausgelagert: In der Grundstellung ist der Teleskoptisch herausgefahren. Er nimmt die eingelegte Palette auf und erfasst dieses über einen Reedkontakt. Anschließend bringt das Regalbediengerät durch gleichzeitiges Verfahren in X- und Z-Richtung die Palette über eine wegoptimierte Fahrstrecke zum vorgesehenen Regalfach. Die Belegung eines Regalfaches wird von der Software erfasst. Um einerseits ein zügiges Hinbefördern, andererseits aber einen gefahrlosen Einlagervorgang zu gewährleisten, sind die horizontalen Regalfachpositionen mit vorgelagerten mechanischen Tastern versehen, die ein Abbremsen des Regalbediengeräts in X-Richtung kurz vor dem Erreichen der Sollposition ermöglichen. Beim Auslagern werden die Ablaufschritte in umgekehrter Reihenfolge durchgeführt. Die X-Achse ihrerseits ist durch eine Hardware-Abschaltung gegen Bedien- und Programmierfehler abgesichert. Das Modul-Hochregallager bietet die Möglichkeit der Kombination mit Modellen (Kombimodelle), um die Peripherie der Anlage zu automatisieren.

The High Level Storage Warehouse simulates an automatically working high-level-storage system as used for example in many industrial branches. The model consists of a rack, being divided up in 3 x 3 storage places and a warehouse operating device, being portable in X-direction. A cage being portable in Z-direction and including a telescopic palette carrier, that is portable in Y-direction, is attached to the warehouse operating device. The simulated process shows pallets being stored and withdrawn from the high-level storage: In the home position the telescopic palette carrier is moved out. In case of the telescopic palette carrier is occupied by a palette, it moves to the station and takes over the palette. This is recognized by a reflection light switch. Following this, the warehouse operating device brings the palette to the intended storage place in an optimized manner by moving in X- and Z-direction at the same time. Occupying a storage place is recognized by software. In order to enable a

quick movement to the storage place on the one hand and a safe lay-in-movement on the other hand, the horizontal rack positions are equipped with advanced mechanical switches that allow retarding the warehouse operating device before reaching the intended position. Withdrawing palettes occurs in the same manner, done in inverse chronological order. Moreover, the X-axes are equipped with a hardware end position switch to prevent the whole warehouse system from fatal mistakes in using the conveyor or programming the control unit. The High Level Storage Warehouse is fit to be combined with further models (Combination models) in order to automate the periphery of the warehouse.

Technische Daten / Technical data:

Versorgungsspannung : 24 V DC
Power supply of sensors and actuators

Sensoren *Sensors:*

Reedkontakt *Reed switches* : 1
 Mechanische Taster *Mechanical switches* : 16

Aktoren *Actuators:*

Motoren mit zwei Laufrichtungen : 3
Motors with two directions
 LED *LED* : 2

Steuerungsanforderungen *Control System Requirements:*

Digitaleingänge (+ lesend) *Digital Inputs (+ reading)* : 15
 Digitalausgänge (+ schaltend) : 8
Digital Outputs (+ switching)

Abmessungen *Dimensions*

(L x B x H) *(W x D x H)* : 550 x 300 x 470 mm
 Gewicht *Weight* : 7,2 kg

Achtung: Zum Betrieb des Modells benötigen Sie eine geeignete Steuerung (z. B. SPS), die nicht im Lieferumfang enthalten ist!

Please note: For running this model you need a special control system (e. g. PLC)!



 Steuerungstechnik

 Anlagen-Maschinenbau

 Simulation

Modell / Model: Kompakt-Hochregallager Compact High Level Storage Warehouse

Elektrische Dokumentation:

- Stromlaufplan
- Steckerbelegung

Electrical documentation:

- Circuit diagram
- Connection plug arrangement

Staudinger GmbH

Schönbühler Str. 5

84180 Loiching

Germany

Tel.: +49 (0) 8731-5069-0

Fax: +49 (0) 8731-5069-60

www.staudinger-est.de

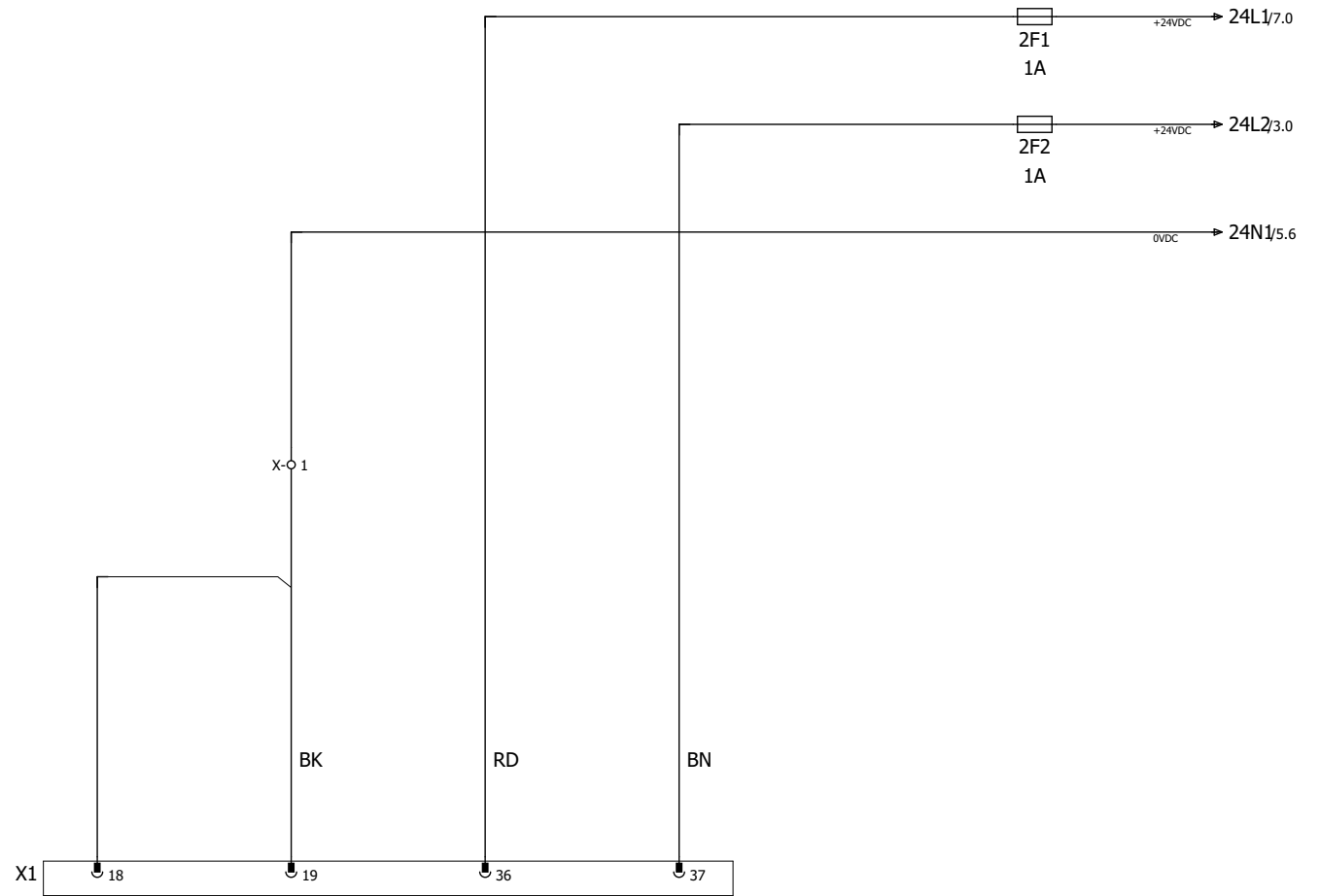

D-Sub Stecker 37-polig / D-Sub connection plug 37 pins

Versorgungs- spannung 0V	Versorgungs- spannung 0V	Versorgungs- spannung Motoren	Versorgungs- spannung Sensoren
Power Supply 0V	Power Supply 0V	Power Supply Motors	Power Supply Sensors

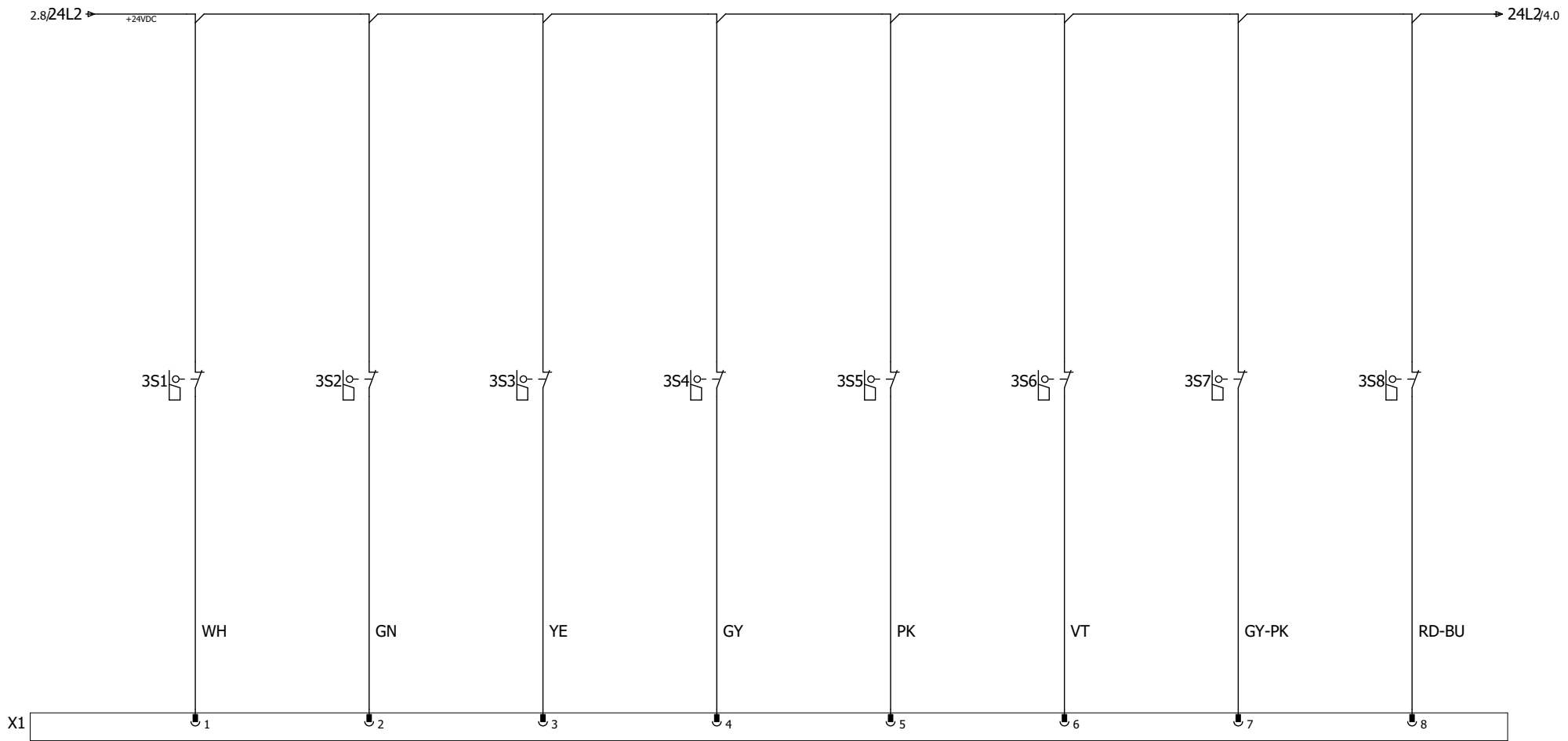

D-Sub Stecker 37-polig / D-Sub connection plug 37 pins

X-Achse Pos. 1 X+	X-Achse Pos. 2	X-Achse Pos. 3 X-	Y-Achse Pos. Y+	Y-Achse Pos. mitte	Y-Achse Pos. Y-	Z-Achse über Pos. 1 Z+	Z-Achse unter Pos. 1
X-Axis Pos. 1 X+	X-Axis Pos. 2	X-Axis Pos. 3 X-	Y-Axis Pos. Y+	Y-Axis Pos. mid	Y-Axis Pos. Y-	Z-Axis above Pos. 1 Z+	Z-Axis below Pos. 1

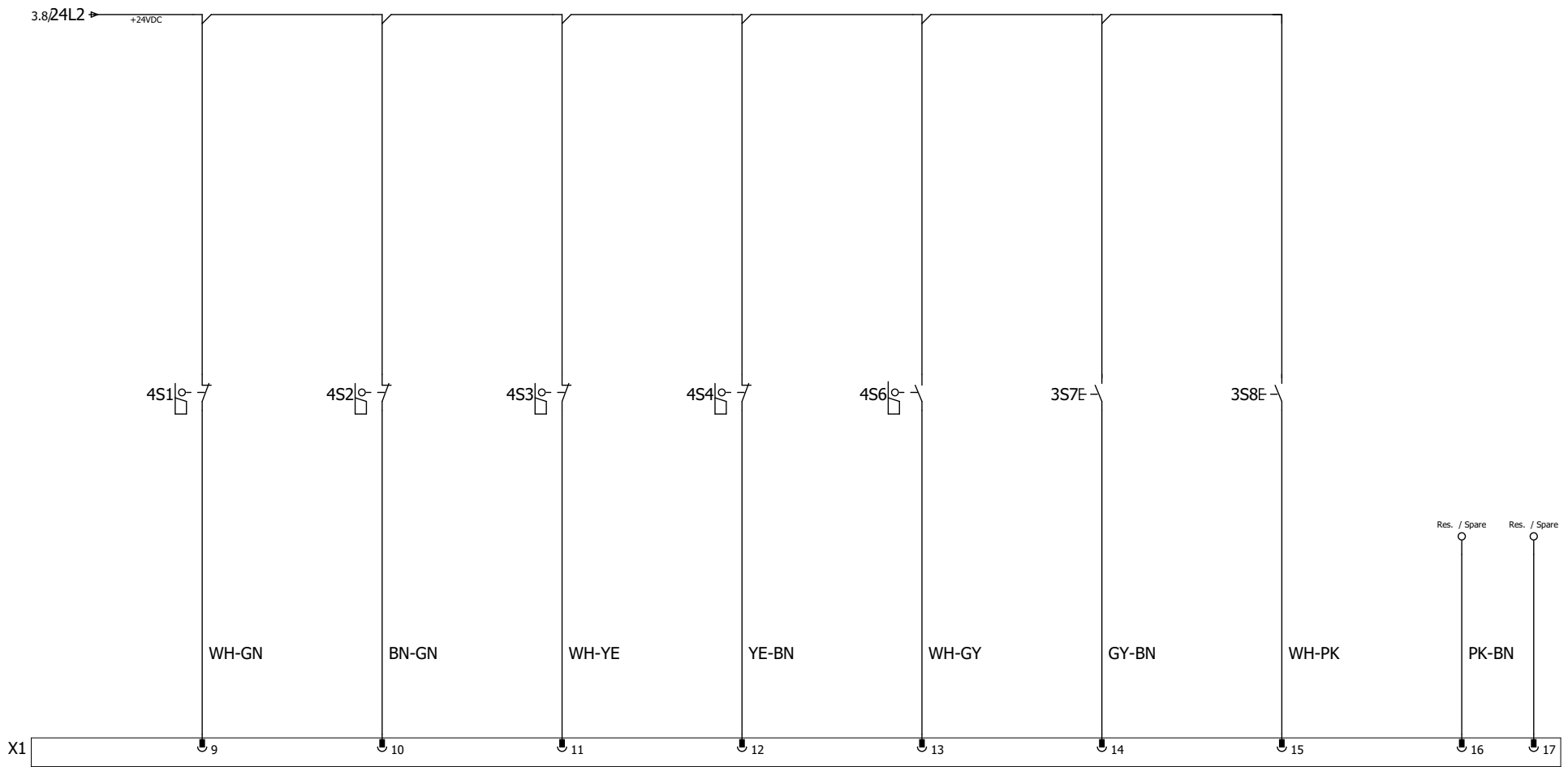

D-Sub Stecker 37-polig / D-Sub connection plug 37 pins

Z-Achse über Pos. 2	Z-Achse unter Pos. 2	Z-Achse über Pos. 3	Z-Achse unter Pos. 3 Z-	Regalbediengerät belegt Rack Feeder occupied	Handtaster 1 Hand Key 1	Handtaster 2 Hand Key 2	Reserve Spare
Z-Axis above Pos. 2	Z-Axis below Pos. 2	Z-Axis above Pos. 3	Z-Axis below Pos. 3 Z-				

D-Sub Stecker 37-polig / D-Sub connection plug 37 pins

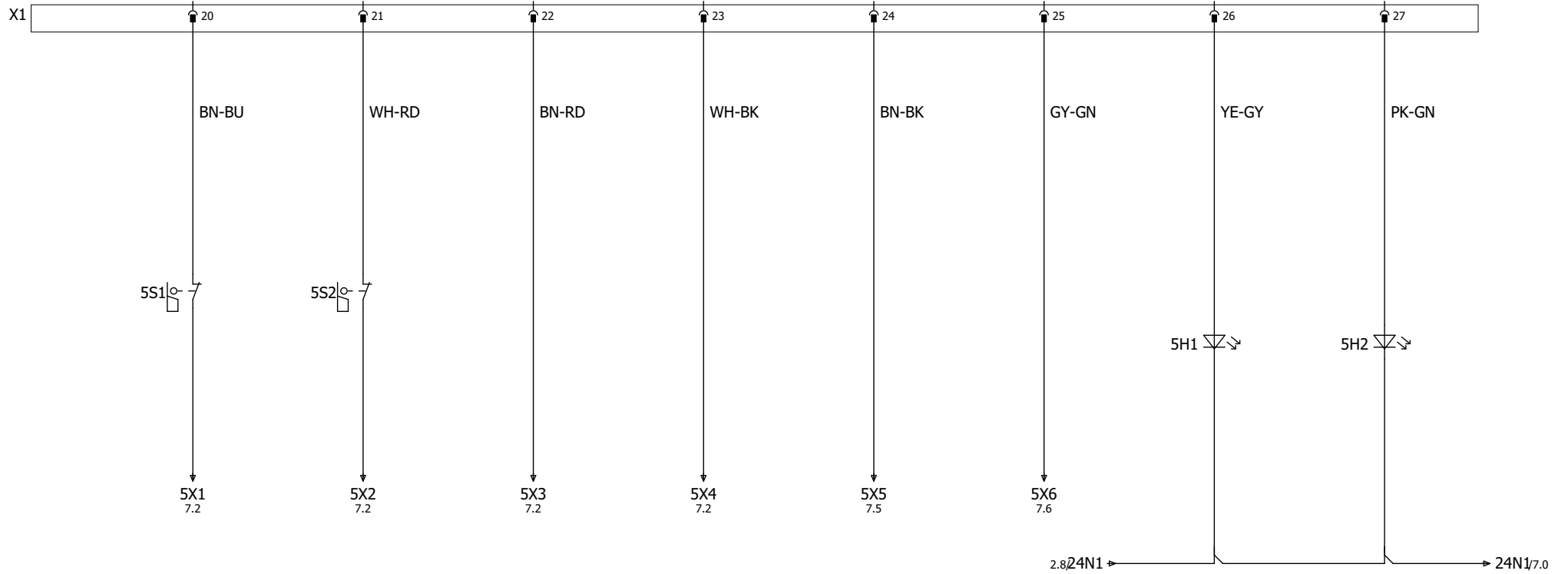

X-Achse nach X+

X-Axis to X+

X-Achse nach X-

X-Axis to X-

Y-Achse nach Y+

Y-Axis to Y+

Y-Achse nach Y-

Y-Axis to Y-

Z-Achse nach Z+

Z-Axis to Z+

Z-Achse nach Z-

Z-Axis to Z-

LED 1 grün

LED 1 green

LED 2 rot

LED 2 red

D-Sub Stecker 37-polig / D-Sub connection plug 37 pins

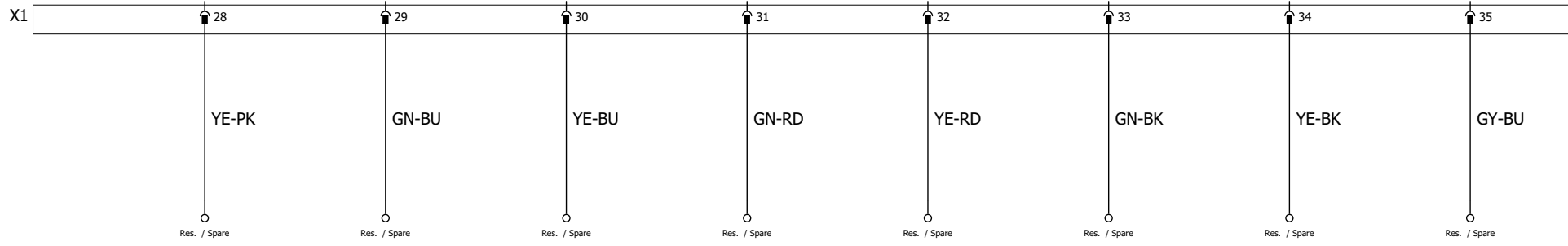

Reserve	Reserve	Reserve	Reserve	Reserve	Reserve	Reserve	Reserve	Reserve
Spare	Spare	Spare	Spare	Spare	Spare	Spare	Spare	Spare

02.05.00	RAI
17.08.06	HEI



Modell / Model
Kompakt-Hochregallager
Compact High Level Storage Warehouse

Benennung / Title
Ausgänge
Outputs

Artikel-Nr. / Article Nr.
226001

2.8/24L1 → +24VDC

5.9/24N1 → 0VDC

5X1/5.1

5X2/5.2

5X3/5.3

5X4/5.4

7A1

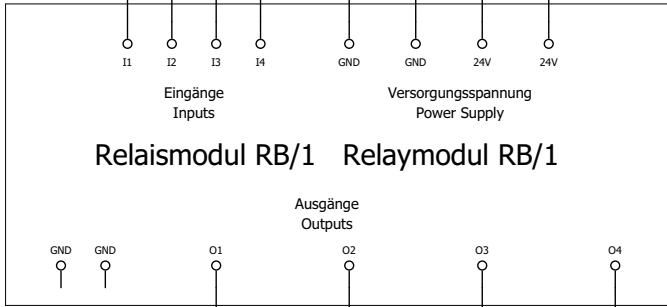

5X5/5.5

5X6/5.6

7A2

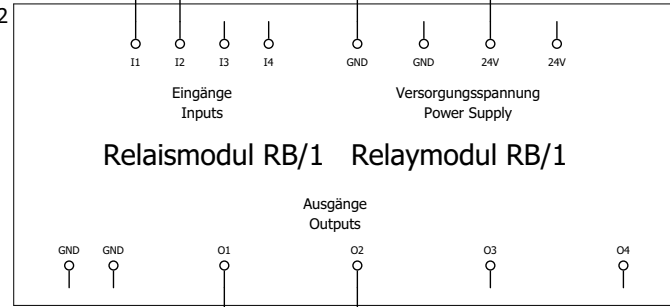

X-Achse

Y-Achse

Z-Achse

X-Axis

Y-Axis

Z-Axis

02.05.00	RAI
18.08.06	HEI



Modell / Model
Kompakt-Hochregallager
Compact High Level Storage Warehouse

Benennung / Title
Relaismodule
Relaymodule

Artikel-Nr. / Article Nr.
226001

Seite / Page
7

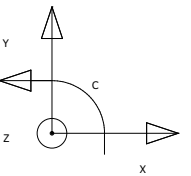
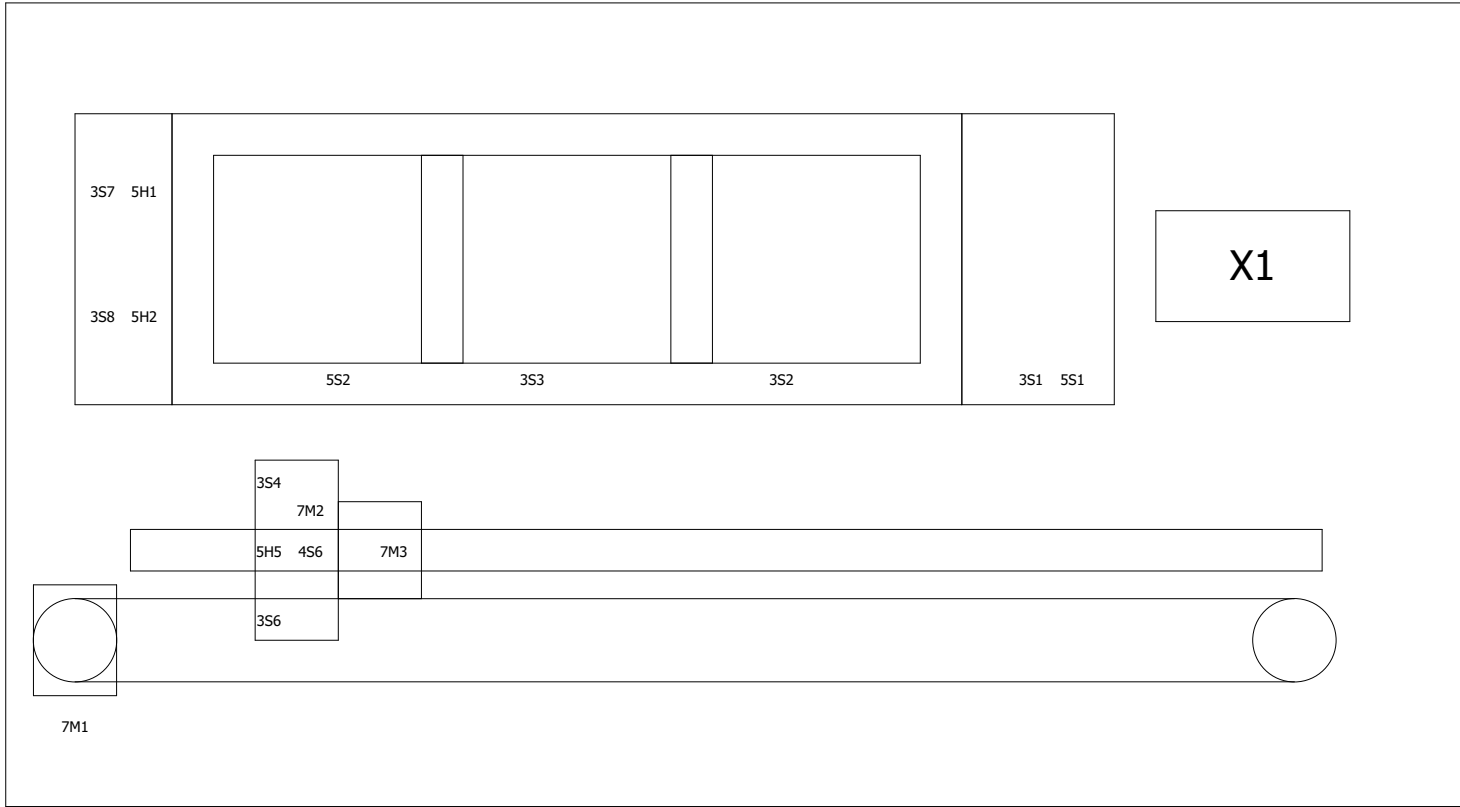

STECKERBELEGUNGSPLAN PIN - OUT - DIAGRAM

Stecker : X1
 Plug : D-Sub Stecker 37-polig
 D-Sub connection plug 37 pins

Pin	Color	I/O	Sensor/Actor	Funktion / Function
1	WH		3S1	X-Achse Pos. 1 X+ / X-Axis Pos. 1 X+
2	GN		3S2	X-Achse Pos. 2 / X-Axis Pos. 2
3	YE		3S3	X-Achse Pos. 3 X- / X-Axis Pos. 3 X-
4	GY		3S4	Y-Achse Pos. Y+ / Y-Axis Pos. Y+
5	PK		3S5	Y-Achse Pos. mitte / Y-Axis Pos. mid
6	VT		3S6	Y-Achse Pos. Y- / Y-Axis Pos. Y-
7	GY-PK		3S7	Z-Achse über Pos. 1 Z+ / Z-Axis above Pos. 1 Z+
8	RD-BU		3S8	Z-Achse unter Pos. 1 / Z-Axis below Pos. 1
9	WH-GN		4S1	Z-Achse über Pos. 2 / Z-Axis above Pos. 2
10	BN-GN		4S2	Z-Achse unter Pos. 2 / Z-Axis below Pos. 2
11	WH-YE		4S3	Z-Achse über Pos. 3 / Z-Axis above Pos. 3
12	YE-BN		4S4	Z-Achse unter Pos. 3 Z- / Z-Axis below Pos. 3 Z-
13	WH-GY		4S6	Regalbediengerät belegt / Rack Feeder occupied
14	GY-BN		3S7	Handtaster 1 / Hand Key 1
15	WH-PK		3S8	Handtaster 2 / Hand Key 2
16	PK-BN		Res./Spare	Reserve / Spare
17	WH-BU		Res./Spare	Reserve / Spare
18				Versorgungsspannung 0V / Power Supply 0V
19	BK		X-	Versorgungsspannung 0V / Power Supply 0V
20	BN-BU		5S1	X-Achse nach X+ / X-Axis to X+
21	WH-RD		5S2	X-Achse nach X- / X-Axis to X-
22	BN-RD		7A1	Y-Achse nach Y+ / Y-Axis to Y+
23	WH-BK		7A1	Y-Achse nach Y- / Y-Axis to Y-
24	BN-BK		7A2	Z-Achse nach Z+ / Z-Axis to Z+
25	GY-GN		7A2	Z-Achse nach Z- / Z-Axis to Z-
26	YE-GY		5H1	LED 1 grün / LED 1 green
27	PK-GN		5H2	LED 2 rot / LED 2 red
28	YE-PK		Res./Spare	Reserve / Spare
29	GN-BU		Res./Spare	Reserve / Spare
30	YE-BU		Res./Spare	Reserve / Spare
31	GN-RD		Res./Spare	Reserve / Spare
32	YE-RD		Res./Spare	Reserve / Spare
33	GN-BK		Res./Spare	Reserve / Spare
34	YE-BK		Res./Spare	Reserve / Spare
35	GY-BU		Res./Spare	Reserve / Spare
36	RD		2F1	Versorgungsspannung Motoren / Power Supply Motors
37	BN		2F2	Versorgungsspannung Sensoren / Power Supply Sensors

